



**SIGNATURE
LIGHTING**

Taco Bell

Case Study



The Design

For this project, the drawings were provided by their designers with a need to finalize the engineering details of the fixtures. Signature recommended a few manufacturing adjustments to make the design a reality (e.g. designing the metal band in the middle to hide the acrylic's seam).

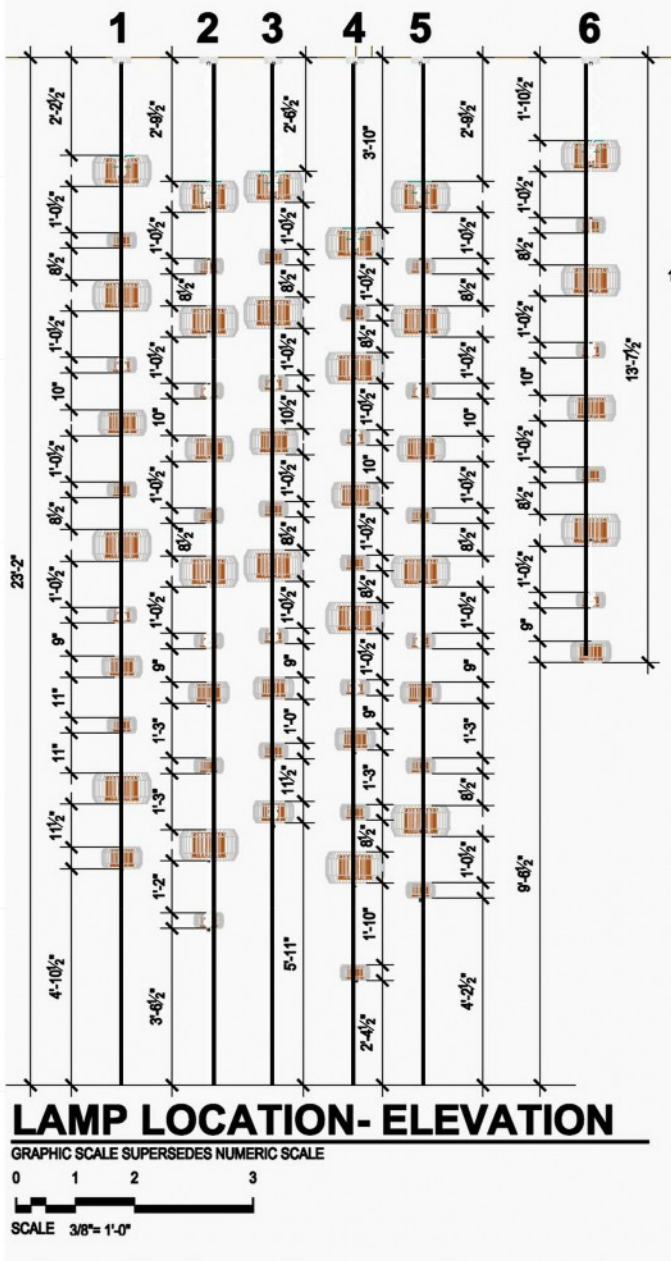
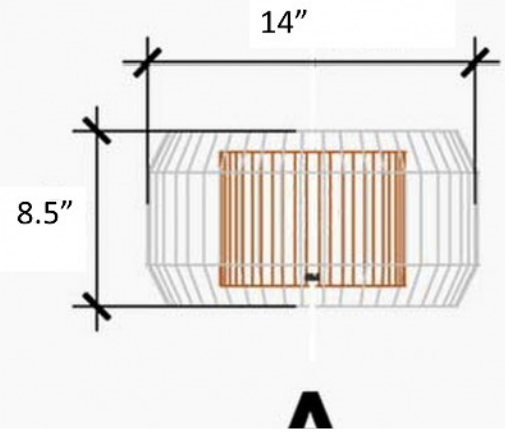

14" diameter acrylic clear shade shade 10" amber shade 14" mold from two halves. Halves are joined and seam is finished with metallic strip. 10" diameter amber acrylic shade rolled and seamed vertically at one joint. For single unit pendent the unit is held by two cable to canopy. Used GU24 Base Socket, does not include lamps.

TACO BELL RSC
 IRVINE, CA

Manufacturer: CUSTOM Design by Luckett & Farley
 Catalog No:
 Lamp: GU Base CF- Self Ballast



A lighting design studio
 within Konsortium1
 www.studiok1.com



The Challenge

Signature had 30 days to complete the project and a limited budget.



The Solution

Speed was key for this order.

Within seven business days, Signature had a sample made and fixtures approved for manufacturing. This allowed for the expediting of all vacuum molds for the acrylic. Within two weeks of sample approval, all the material had arrived to their shop for assembly. By the fourth week, assembly was completed and the fixtures were shipped to the site.

This project is showcasing how nimble Signature can be when tasked with a tight deadline, while still producing a quality product.





For more information or to get in touch, visit:

Signature-Ltg.com